

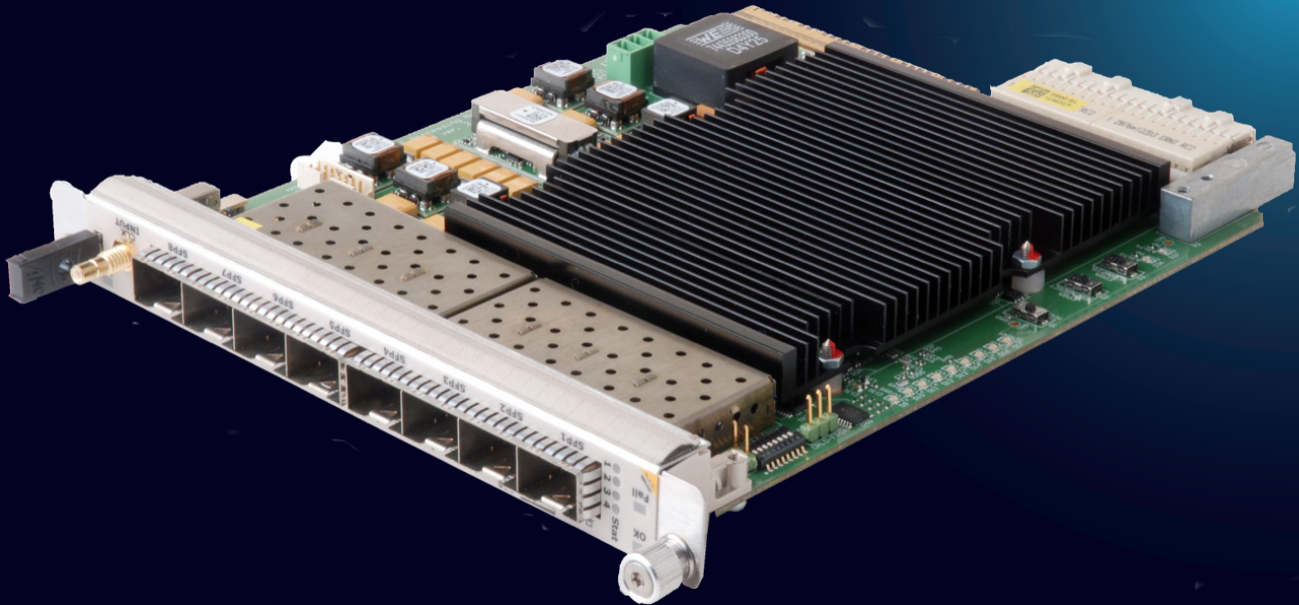

# NAT-AMC-TCK7

## Data Processing AMC Module for MTCA & ATCA



The NAT-AMC-TCK7 is a high-performance, low-latency data processing Advanced Mezzanine Card (AMC) based on the Xilinx® Kintex™-7 FPGA, which provides industry-leading performance-per-watt. The N.A.T. module combines processing power, memory, communications links and reference clock signals in a double-width, mid-size MicroTCA.4 AMC form factor. Developed with DESY, the Deutsches Elektronen-Synchrotron, and already deployed as a low level radio frequency (LLRF) cavity field stabilizing controller, the NAT-AMC-TCK7 is suitable for a range of data processing applications from wireless network remote radio head to software-defined radio (SDR). It provides a number of low latency links via the front panel, the backplane and a rear transition module (RTM), with up to 10 Gbps\* throughput.

### Key features

- Double-width, mid-size MicroTCA.4 AMC (full-size option)
- Xilinx® Kintex™-7 FPGA (XC7K355T or XC7K420T)
- Partial reconfiguration and firmware upgrade support
- 4x4Gb 1066 Mbps 64-bit DDR3 SDRAM
- 8x10 Gbps\* SFP+ external interfaces
- Clock distribution circuit

### Applications

- High Energy Physics Research
- Wireless Remote Radio Heads (RRH)
- Software Defined Radio (SDR)
- LTE Baseband Processing
- Avionics Video Distribution System

\* 12.5 Gbps possible with Xilinx® Kintex™-7 speed grade -3



# Technical Data

## NAT-AMC-TCK7

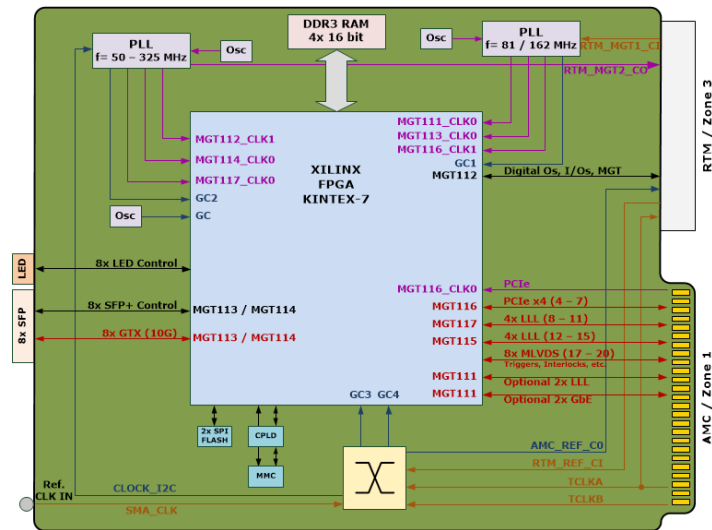

## Overview

The NAT-AMC-TCK7 from N.A.T. is a double-width, mid-size AMC for general-purpose data processing that combines low latency digital signal processing, memory, communications links and reference clock signals.

### Processor

Xilinx® Kintex™-7 FPGA XC7K355T (default) or XC7K420T (option). In default assembly option the FPGA offers 24 multi-gigabit transceivers, which support bit-rates up to 12.5 Gbps\*. The FPGA also supports PCIe Gen2 communication, so the x4 link can provide a throughput of 20 Gbps.

### Memory

For temporary data storage the NAT-AMC-TCK7 features four SDRAM DDR3 memory chips, each with a capacity of 4Gb (16 Gb in total), operating with a data rate of 1066 Mbit/s and a width of 64 bit. The memory circuits share the address and control buses.

For permanent data storage, the NAT-AMC-TCK7 is equipped with a Quad SPI FLASH containing the FPGA bit stream; the memory space beyond the bit stream is available for user application.

### Connectivity

#### Front Panel

The front panel provides MTCA.4 standard compliant retention devices,

handle, and three IPMI LEDs as well as four LEDs for FPGA application free use. Up to eight optical fibre SFP+ connections provide low-latency connections to, for example, LLRF components. A reference clock signal can be received via a SMB connector.

The NAT-AMC-TCK7 features a MicroUSB connector which provides access to diagnostic UARTs (RS232-via-USB). The debug interface enables low-speed data transmissions to the MMC and FPGA circuits.

### Backplane (Zone 1) AMC

The Zone 1 connector provides eight low-latency communication links to, for example, the ADC boards, a PCIe interface to the controlling CPU, M-LVDS bus signals, and other signals required by the AMC standard. The two 1 GbE-channels and low latency links on ports 2 and 3 are available for the XC7K420T-FPGA only. The connector is compatible with the double-row B+ connector specified in the AMC base specification with extensions required by PICMG MTCA.4.

### Backplane (Zone 3) RTM

The Zone 3 connection provides low-latency links to the RTM (in case of a LLRF system it could be for example, a vector modulator), general purpose parallel bus (LVDS levels), output signals

(interlocks), reference clock inputs and outputs for GTX, and digital logic and other signals required by MTCA.4. The NAT-AMC-TCK7 can be connected to an RTM using two 30-pair ADF connectors. The Zone 3 classification is Class D1.2.

Compatible RTM products: DRTM-VM2 (2 channel high or low frequency Vector Modulator), DRTM-AD84 (8 channel 16bit, 10MSPS ADC, 4 channel 16bit 10MSPS DAC) DRTM-PZT4 (4 channel Piezo driver).

### Clock

The clock distribution circuit provides a broad range of reference frequencies for high-speed serial interfaces, including DESY LLRF, PCI Express, Fibre Channel, Infiniband, GigE, 10 GigE, 10-G Fibre Channel, 12 GigE, 10GBASE-R, 10GBASE-X, and XGMII.

### CPLD

The NAT-AMC-TCK7 features a XILINX XC2C256 CoolRunner-II CPLD. This device is used for support functions such as multiplexing and switching of SPI and JTAG lines, as well as for driving status LED.

## Specifications

### Processor

- Xilinx® Kintex™-7 FPGA XC7K355T (default) or XC7K420T (option)

### RAM

- DDR3 SDRAM (256M x 64 bit)

### PROM

- QSPI FLASH (2x 256 Mbit)

### Operating System Support

- Linux operating system

### Environmental Conditions

#### Temperature (operating):

- 0°C to +50°C with forced air cooling

#### Temperature (storage):

- -40°C to +90°C

#### Relative Humidity:

- 5% to 90% rh non-condensing

### Power Consumption

- 12V / 6.5A max

### Standard Compliance

- AMC.0, AMC.1, AMC.2, MTCA.4, IMPI V2.0, MMC V.0 compatible, EN60950, UL1950, CE, RoHS, REACH